



Cast	Theme
Steel	Folding
Stainless	Custom
Ram Raid	Plastic
Telescopic	Composite
Removable	Illuminated
Barriers & Gates	Cycle Stands
Pavement Protection	Retail Systems

Bollards

CAST BOLLARDS

Bollards are found today in many urban landscapes. They are mainly used to prohibit the use of vehicles within given areas. Often the use of bollards makes pedestrians feel less vulnerable to the passage of traffic in close quarters.

CIS Street Furniture specialises in producing a vast range of bollards as shown throughout this section of the brochure.

We have over twenty different designs available from stock.

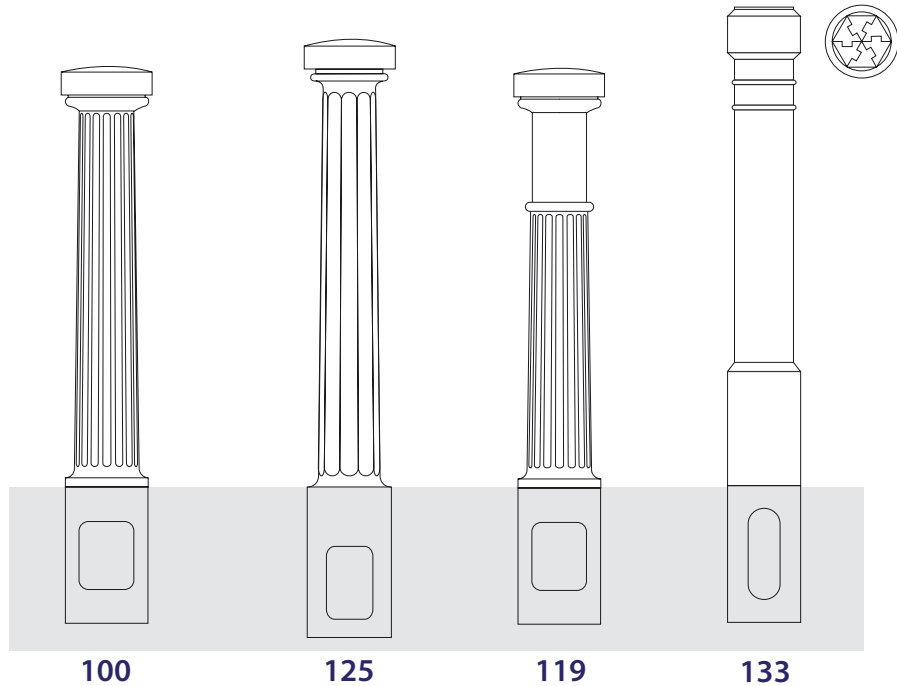

Product dimensions

	height mm	base diameter mm	root depth mm
100 *	925	142	300
125 *	985	142	330
119 *	925	182	300
133	1050	160	300
101 *	800	180	300
103 *	1100	218	300
111 *	1200	210	300
112 *	970	185	500



* stock products



Bollards

CAST BOLLARDS

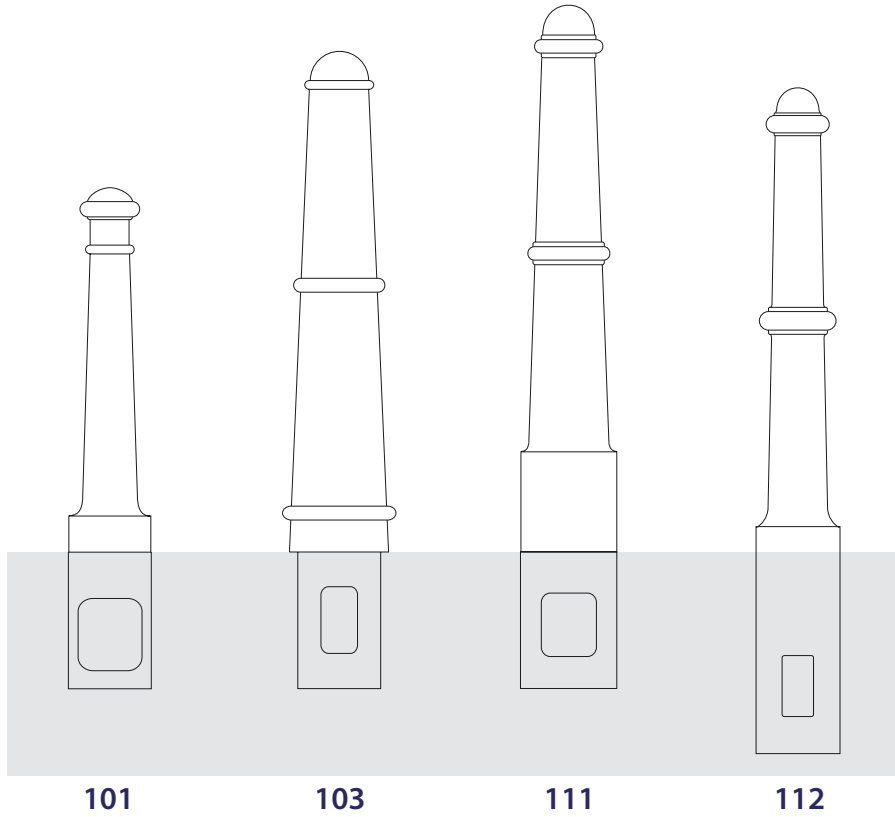

Cast iron is the ultimate recyclable material and most bollards will last 50-100 years even unpainted. A popular myth regarding the use of cast iron is that of corrosion. How many times have you heard that 'cast iron rusts'?

This statement is only partially correct.

Unpainted cast iron will lose only around five microns per year. When treated with CIS Street Furniture standard 2-pack epoxy acrylic paint system (specially formulated) it has 5-10 years to first maintenance (subject to service conditions).



101



111



103

CAST BOLLARDS

Types 120 and 126 are heavy duty bollards. Their weight makes them unsuitable for use as removable bollards.

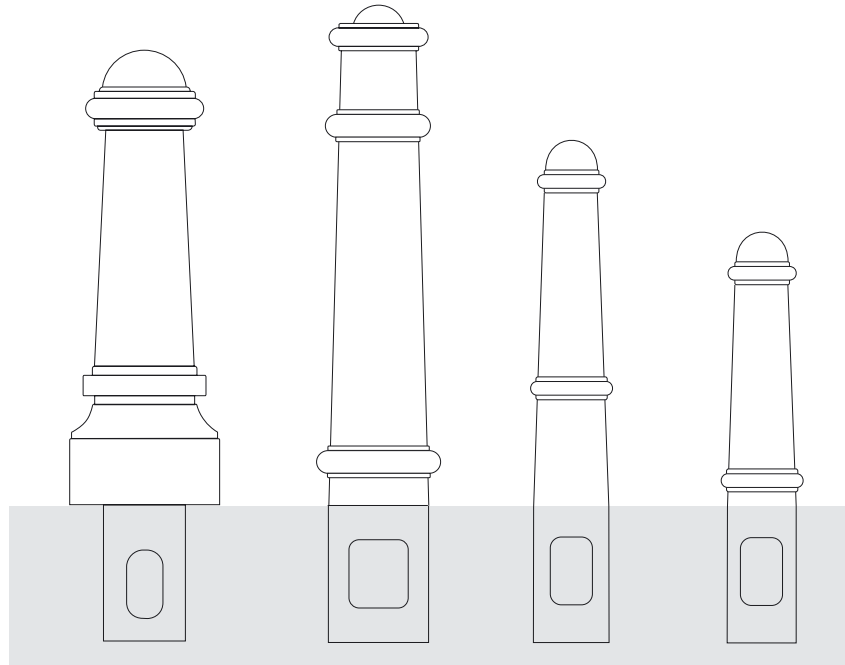

120

126

129

130



Product dimensions

	height mm	base diameter mm	root depth mm
120	1000	330	300
126 *	1100	220	300
129 *	800	167	300
130 *	600	152	300
106 *	1000	220	300
106Q	1000	220	300
118 *	660	200	200
135	1100	175	300

* stock products

Bollards

CAST BOLLARDS

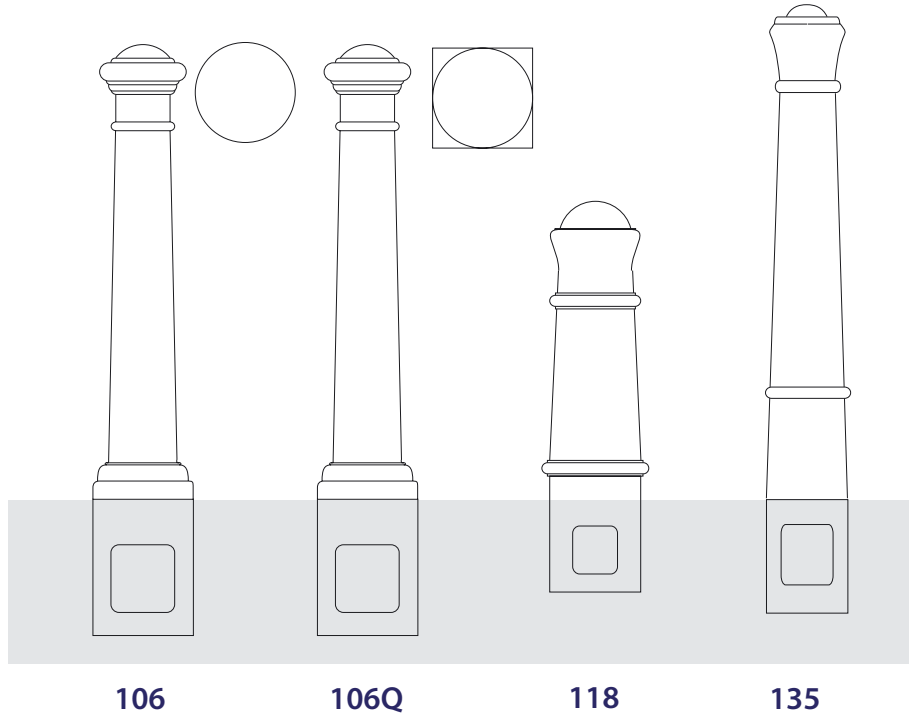

The 106 is one of our best selling bollards and is available from stock. To help fit angular paving styles we have created a square based version 106Q, made to special order.

All products are available primer painted or fully painted in 2-pack epoxy acrylic, factory applied by airless spray. The full RAL or BS4800 colour range is available. Highlighting in a contrasting colour can be provided on most products.



CAST BOLLARDS



121

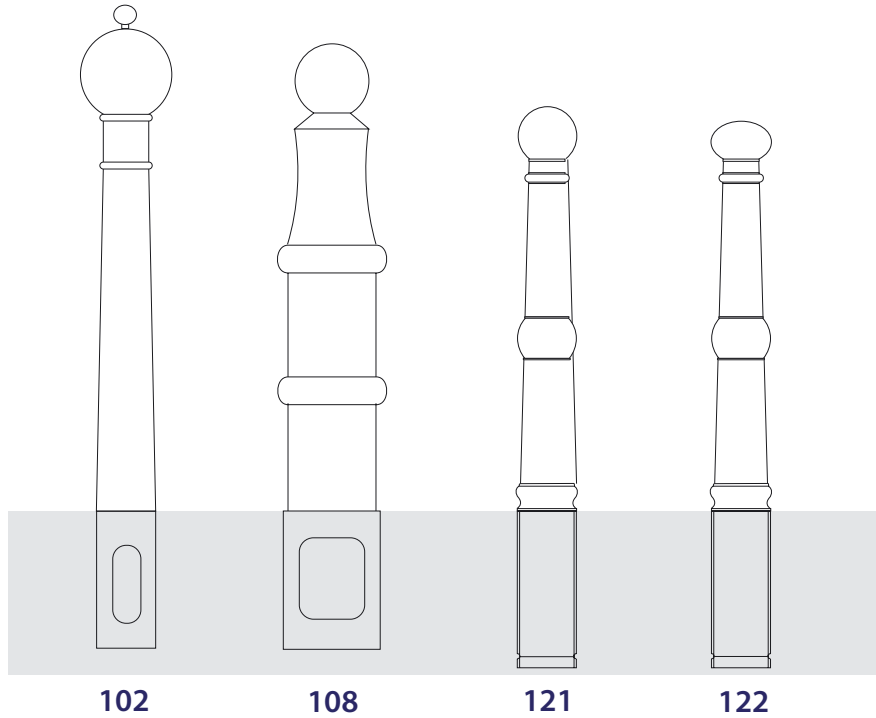

The 102 is called a "Chippenham" bollard and has been brought to life by North Wiltshire District Council. Based on an old traditional design found in the town during the early 1900, this bollard has been replicated by CIS Street Furniture based upon photographs alone.



108



108

Bollards

CAST BOLLARDS

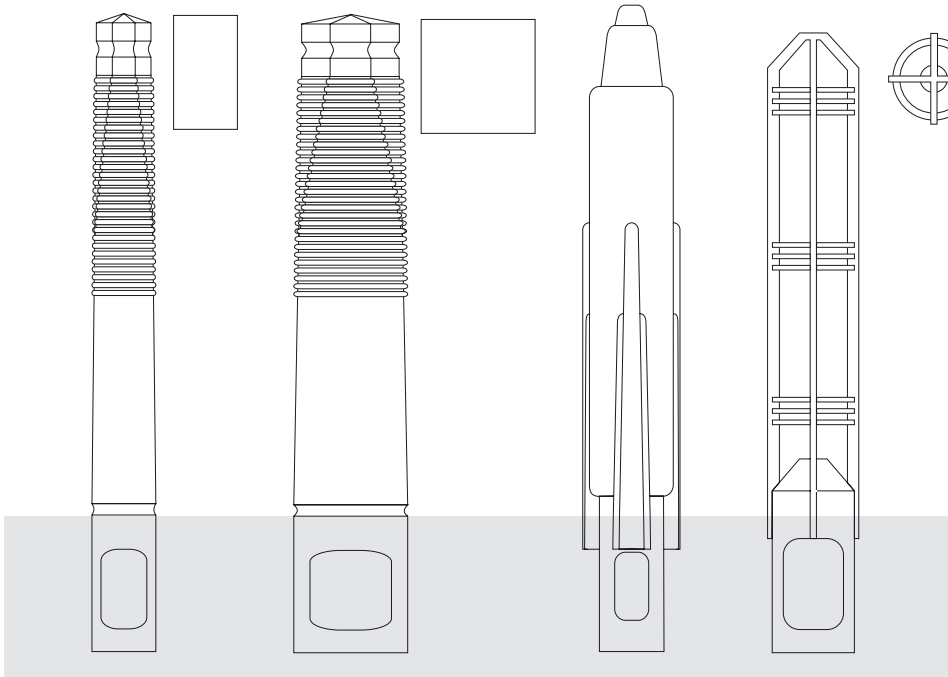

104

124

131

132



132



104

Product dimensions

	height mm	base diameter mm	root depth mm
102	925	182	300
108 *	1010	190	300
121 *	890	120	345
122	885	120	345
104 *	1100	140/250	300
124	1100	250/250	300
131	1120	185	300
132	1060	200	300

* stock products



104

CAST BOLLARDS

Product dimensions

	height mm	body diameter mm	root depth mm
113	1050	225	300
117	245	220/300	-
127	1100	180	300
128*	760	150	300
138	1100	140	300
141	900	140	300
144	900	140	300
145	900	125	300
139	1100	140	300
140	900	125	300
143	900	140	300
146	860	230	300
147	900	230	300
148	900	125	300
149	900	125	300

* stock product

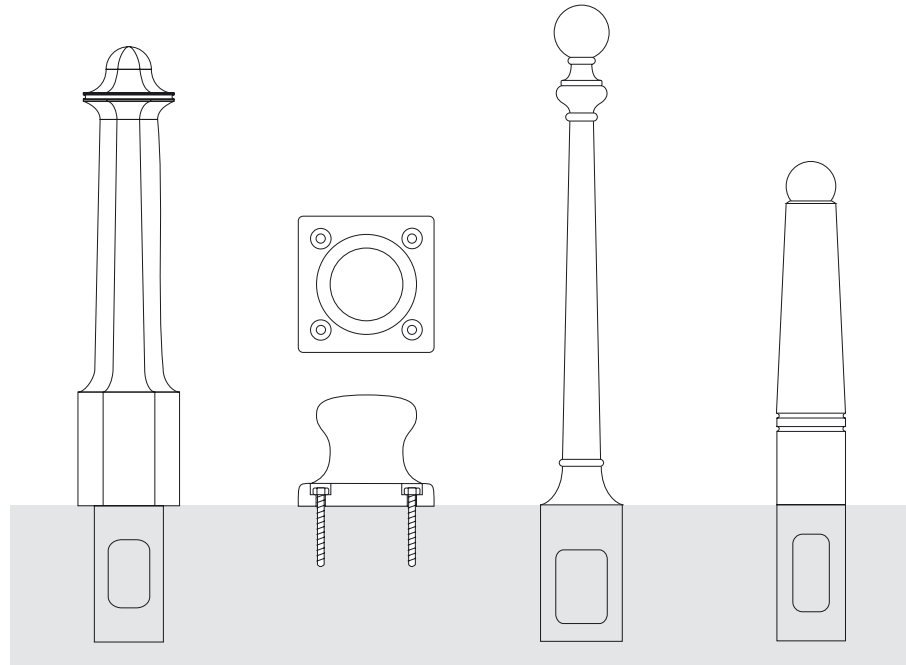

113

117

127

128



128



113

Bollards

CAST BOLLARDS

The range of contemporary styled bollards shown on this page gives the specifier the option of being ever more daring in Urban Design.

Why not design your own bollard? CIS Street Furniture can give you advice on shapes, styles and manufacturing methods. Contact our sales office for further information.

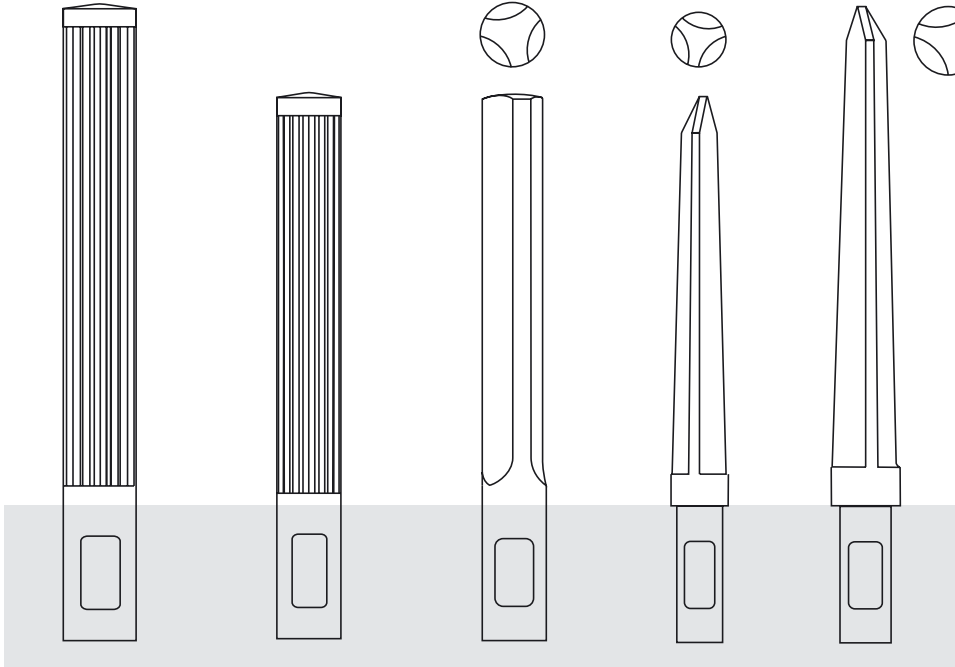

138

141

144

145

139

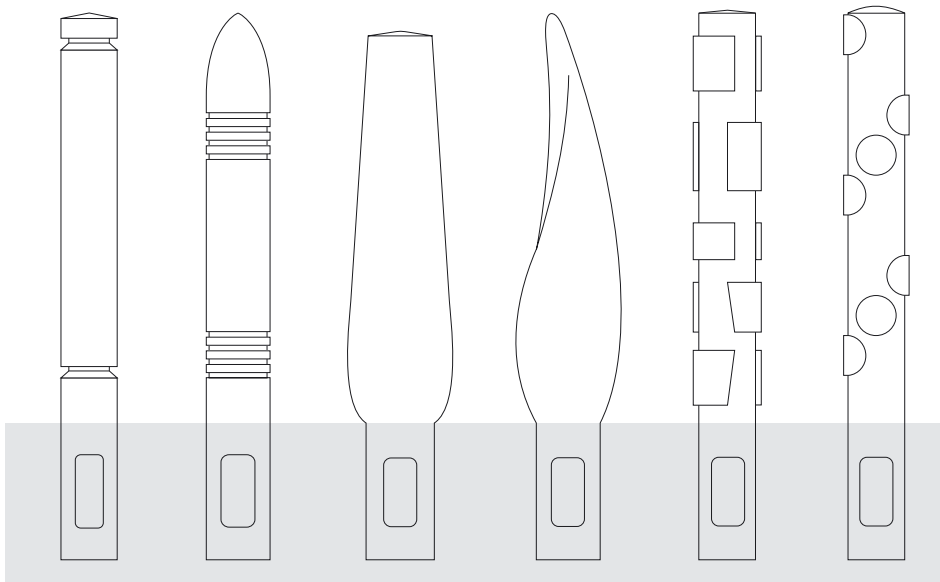

140

143

146

147

148

149



147

143 is a composite bollard with steel base and cast head.

CAST BOLLARDS

Vehicle control is a must in leisure areas. Here, additional interest and a distinctive style may be extended to areas by the use of our continually developing range of theme bollards.

Remember quality and performance is not compromised by innovative design.



160



169

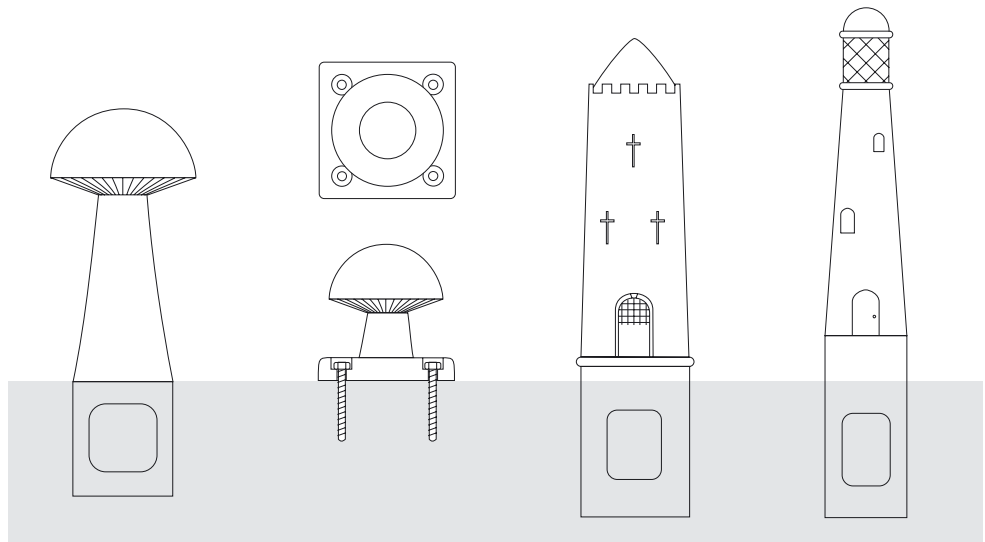

160

161

162

163

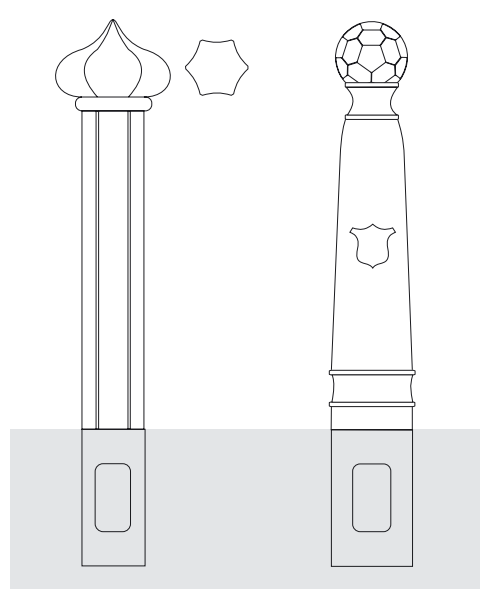

164

169/1

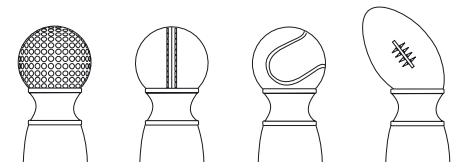

169/2

169/3

169/4

169/5

Product dimensions

	height mm	body diameter mm	root depth mm
160	600	320	250
161	300	300/300	-
162	750	240	300
163	820	180	300
164	900	135	300
169/1	900	180	300
169/2	900	180	300
169/3	900	180	300
169/4	900	180	300
169/5	950	180	300

Bollards

BASE SOCKETS



Bollards can be made removable in a variety of ways. Shown here are our 191 and 192 base sockets which can be used with most of our bollards.

191 uses a hinged lid to permanently locate the bollard. The unit is secured by your padlock to prevent unauthorised removal.

The socket 192 uses a separate cover plate that is stored within the base when the bollard is fixed. On removal, the plate can be replaced and locked, giving a flush-fitting surface.

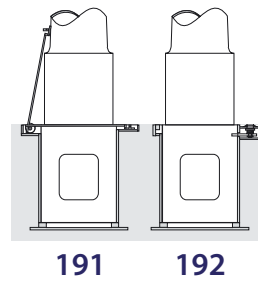

BAYONET SOCKETS

Our new socket design 190 has been created to make bollard removal easier. Bollards are located at ground level by a simple quarter turn into a special ground box. The lockable peg renders the bollard immovable. A cover plate, stored separately, can be fitted when the bollard is removed.

An alternative ground box can be supplied as a bolt down unit should underground services prevent a rooted unit.

COMPOSITE BOLLARDS

The combination of castings and steel in this range permits a great diversity in size and strength whilst retaining style elements from some of our cast bollards.

All composite bollards are available in three standard heights: 750, 900 and 1100mm.

The standard root depth is 300mm but this can be varied to suit ground conditions.

The composite method of manufacture allows a greater degree of flexibility of design. These bollards can be customised by moving or adding features such as extra rings or introducing height changes to the standard shown.

All steel is fully galvanised to BS729 prior to the application of primer paint or two pack epoxy acrylic top coat.

Bollards

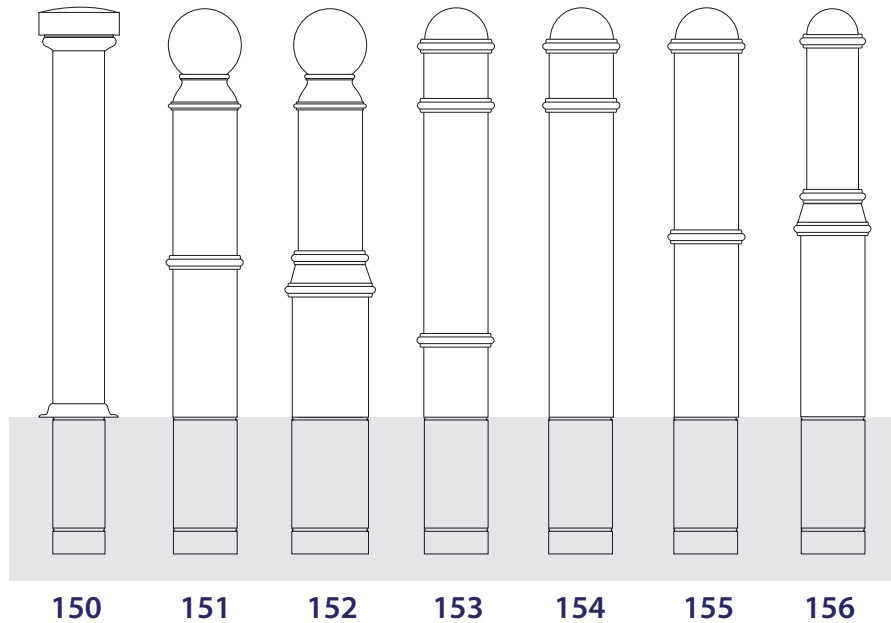

Ordering codes: S=750mm, M=900mm, T=1100mm



153



155



153

Bollards

COMPOSITE BOLLARDS

Bollards may be customised by the use of logos, crests or wording in order to incorporate features such as parking restrictions and other small information plaques. Reflective tape may be added to bollards to give high visibility in vehicle headlights.

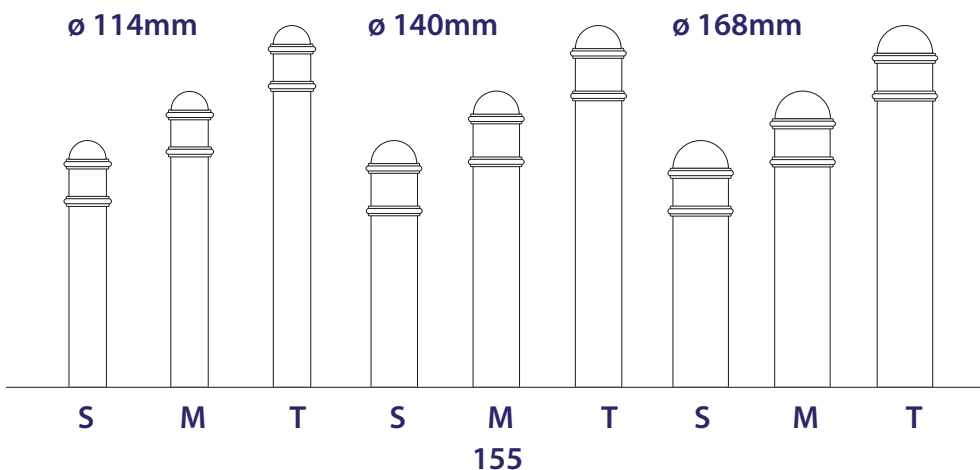
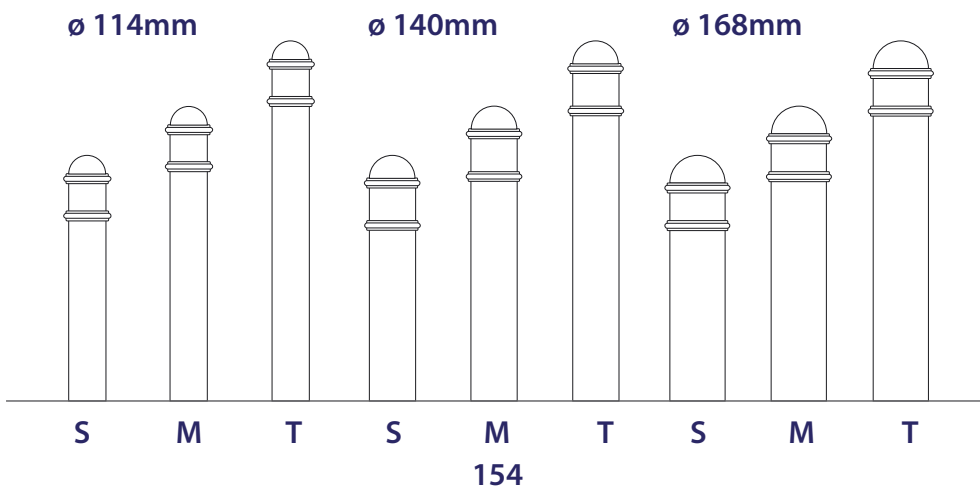
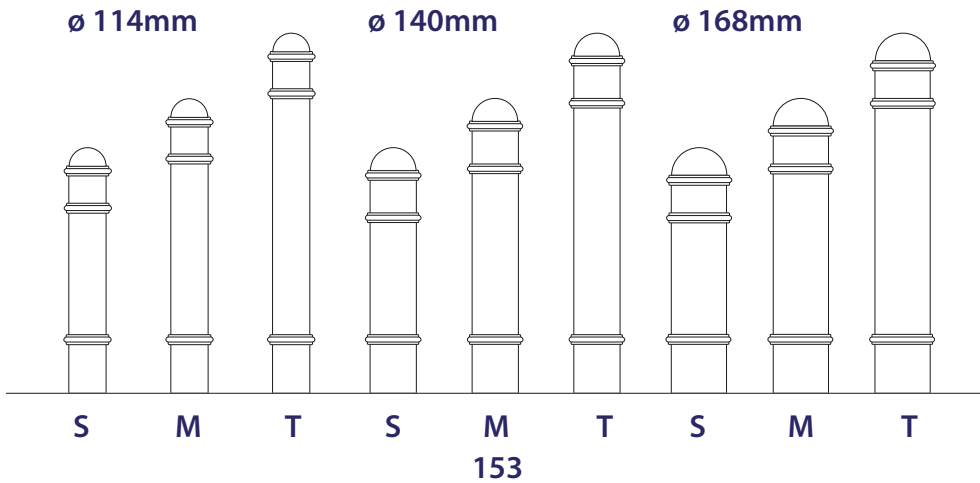

Product availability

	ø 114mm	ø 140mm	ø 168mm
150	✓		
151		✓	
152	✓	✓	✓
153	✓	✓	✓
154	✓	✓	✓
155	✓	✓	✓
156	✓	✓	



COMPOSITE BOLLARDS

Bollards shown here have a more contemporary style.

Types 1501 - 1503 are budget bollards and are available at extremely competitive rates. We can supply with or without the loose fitting cover plate type 1550.

Product dimensions

	height mm	body diameter mm	root depth mm
157	1100	127	300
158	930	168	360
1501 *	900	114	300
1502 *	900	114	300
1503 *	900	114	300
1504	1025	114	300

* stock products

Bollards

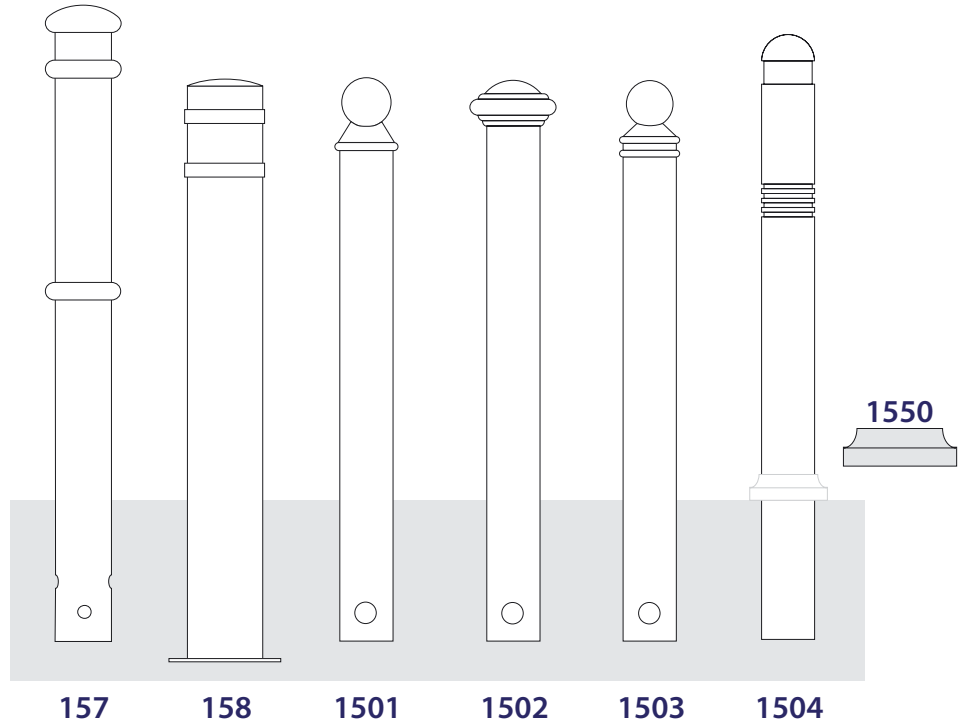

1504



157



1501 + 1550

Bollards

PAVEMENT PROTECTION



Careful design led to an almost iceberg like shape, transmitting loads across a wide area. Casting in ductile iron makes it virtually unbreakable.

Below: just the situation our 193 bollard is designed to prevent.



The 193 pavement protection bollard has been developed with local authority engineers, who in the past had to deal with the after effects of vehicles mounting pavements leading to damaged paving, bent guard railing, loosened kerb stones and injured pedestrians.

The 193 is very useful on tight curves, entrances to buildings and industrial estates or to protect equipment like traffic lights and fuel pumps.

The shape is designed to integrate with the kerb, being very slim above ground and taking up little pavement area, so giving an uncluttered look to the narrowest of pavements.

The kerb face profile suits standard half batter concrete kerbs to BS7263 part 1:1994.

RAIL & CHAIN

The use of rail or chain with standard bollards can add some pedestrian control without changing design.

Virtually all bollards may be fitted with chain, many will take rail.

STEEL BOLLARDS

Steel bollards are a very effective means of basic vehicle control. The simple styling makes them particularly suitable for use around contemporary buildings.

The lower cost of construction make these types a favourite choice for budget schemes.

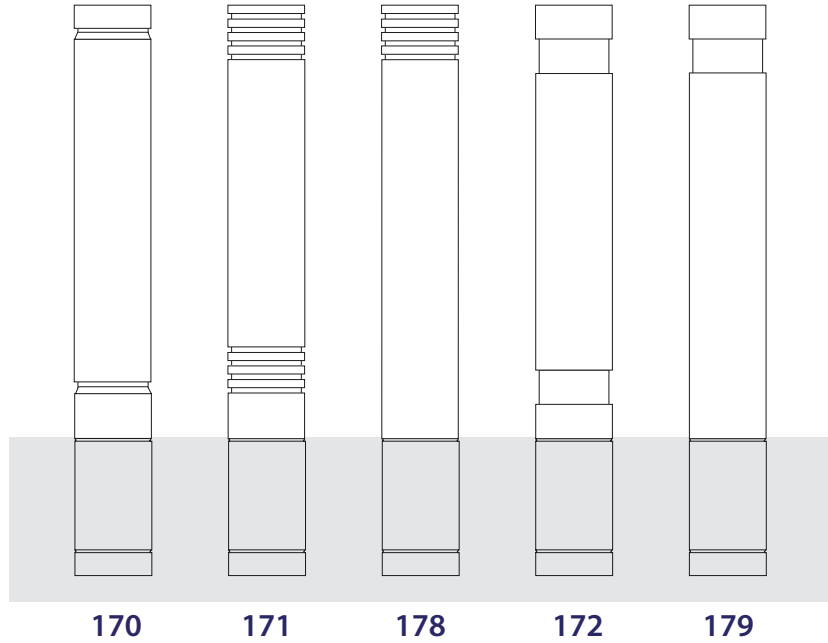

Bollards



STEEL BOLLARDS

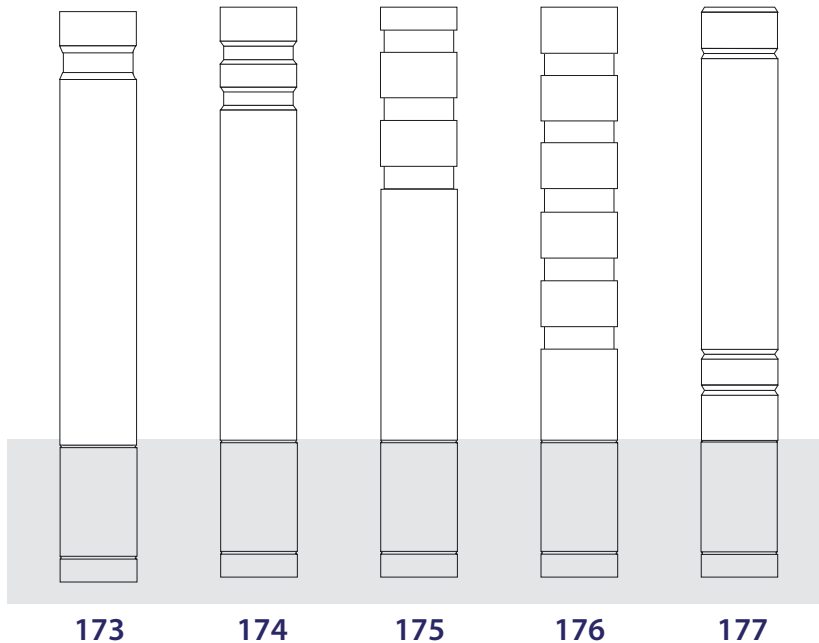

173

174

175

176

177

Types 170 to 179 are all available in four diameters and five standard heights. Illustrations are shown on page 1.18.

Root depth, normally 300mm, may be varied to suit ground conditions.

Flanged versions are also available in place of roots.



All steel bollards within this range are manufactured from 10mm wall thickness steel tube. Recesses and caps are all fully machined giving exemplary levels of appearance. Bollards are also fully galvanised to BS 729 prior to either priming or fully painting in our 2-pack epoxy acrylic paint system. A full range of RAL or BS colours is available.

Bollard types 173,174,178 & 179 are anti ram-raid bollards as standard. As there are no lower recesses, these bollards as standard will absorb a spot impact of some 30 tonnes (subject to suitable foundations)



174 F

STEEL BOLLARDS

Types 170 to 177 are all available in four diameters and five standard heights. We have illustrated all twenty variants of the 173.

Ordering height codes

- A = 535mm
- B = 640mm
- C = 770mm
- D = 950mm
- E = 1200mm

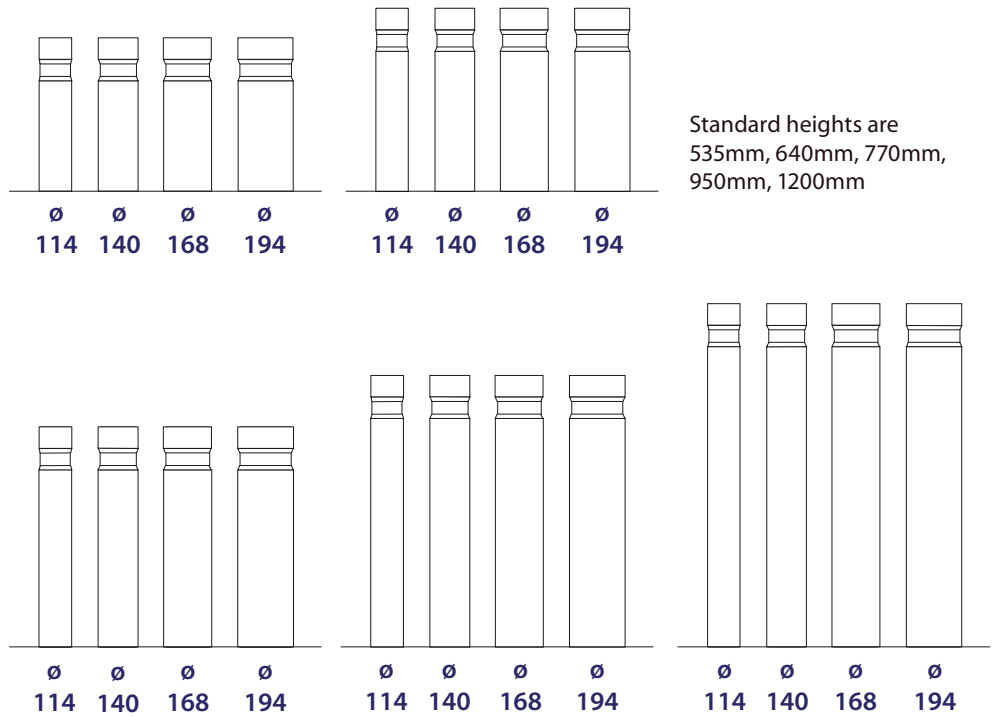

POWER TAKE-OFF OPTIONS

A wide range of bollards are available for use as power take off bollards. A lockable door is provided along with a marine plywood backboard. The bollards are able to take a varying range of electrical equipment fitted by the customer.

Product availability

- 103 see page 1.3
- 106 see page 1.5
- 108 see page 1.6
- 115 see page 1.19
- 126 see page 1.4
- 170 - 179 194mm \varnothing , all heights.
See top of this page

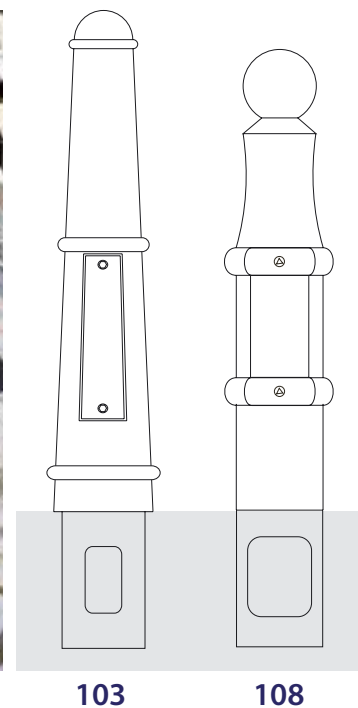

Bollards

CUSTOM BUILD

The 115 and 115i bollard were designed by the artist Tess Jaray for Leeds NHS Trust and have been used within Jubilee Square at the Leeds General Infirmary. The engineering design, pattern making, casting and finishing were the responsibility of CIS Street Furniture.

Also incorporated in the design is an illuminated version that features integral gear and lamps. All photographs and drawings appear by kind permission of Leeds NHS Trust and the artist Tess Jaray.

Many other bollard designs have been produced as custom build. For information or design help, please contact our Sales Department.

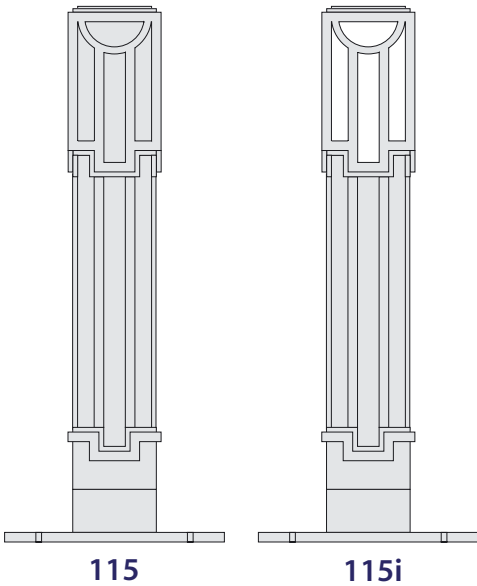

ANTI-RAM RAID PROTECTION

194rr is a fold down bollard which can be locked in the up position or tucked neatly into a box when not required. As shown in the photographs it will absorb the impact of a car quite satisfactorily. This vehicle was rendered immobile with one bollard piercing the passenger footwell.



Photos courtesy of the Burton Daily Mail

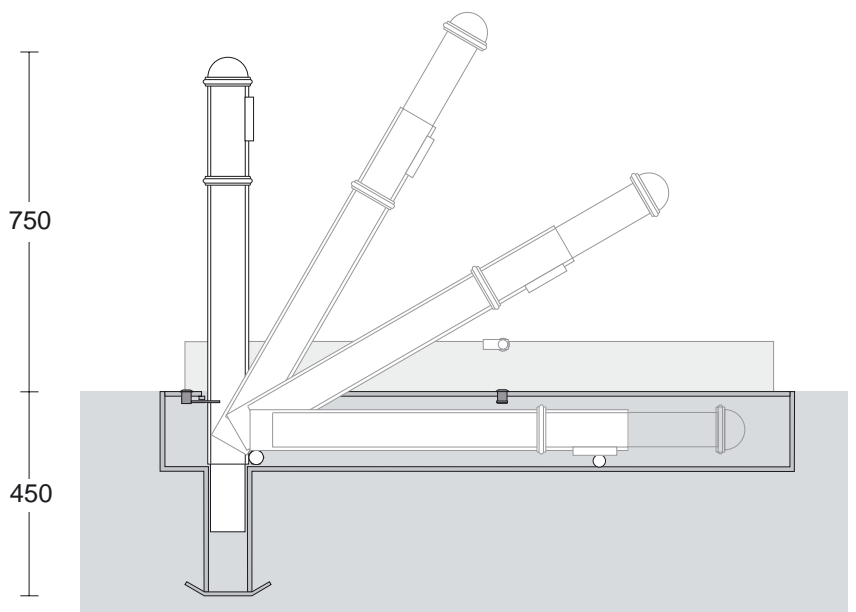

194rr

Bollards

ANTI-RAM RAID PROTECTION

A more cost-effective alternative is the strengthening of cast bollards by the addition of a core to the inner section of the bollard. Two options are available.

Core only (199x): A steel core is bonded to the inside of the bollard with sand and cement. This extends the bollard root to approx. 500mm. This should then be fixed to a suitable foundation.

Full System (199): A steel core is added to a bollard as above. Also supplied is a below ground metal casing. The bollard is set in the casing and packed with pea gravel. The top quarter is concreted as normal. The impact of a motor vehicle will be absorbed such that the bollard will deflect to an angle of approx. 40 degrees to the ground. This should render the vehicle immobile.

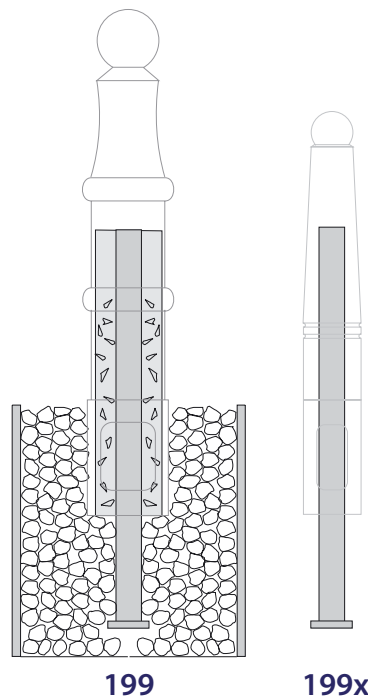
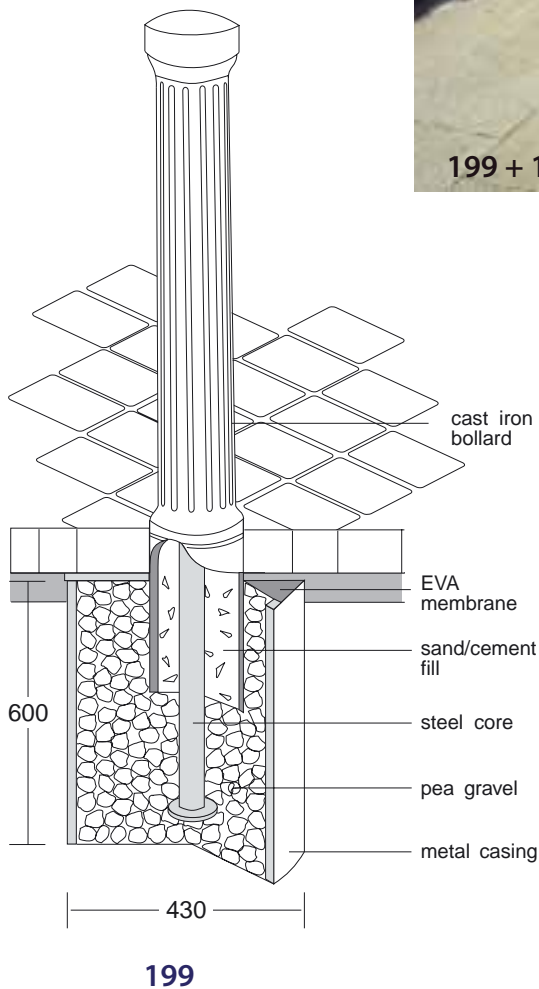

COVER PLATES

Cover plates are available to fit most bollard types. These are particularly useful in hiding the transition of square paving to round bollards.

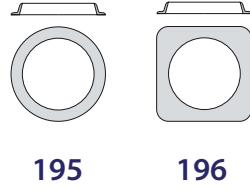

ILLUMINATED BOLLARDS

A full range of illuminated bollards is available, details of which are shown in section 6.0 of this catalogue.



HOOP BARRIERS

Hoop barriers are an effective method of preventing vehicle access. 350 is a simple barrier designed to be fixed in a concrete base available in three diameters: 48mm, 60mm and 89mm.

351 offers the same specification but has the added versatility of being removable, leaving a flush fitting ground box. This is particularly useful on garage forecourts.

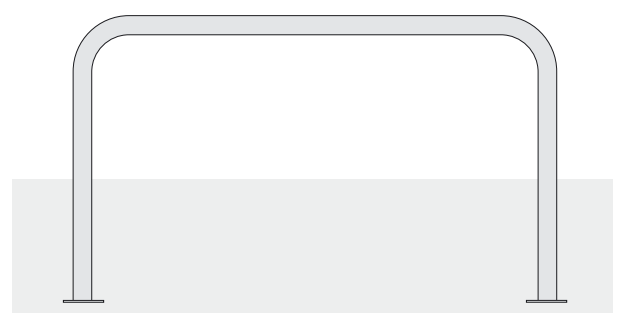
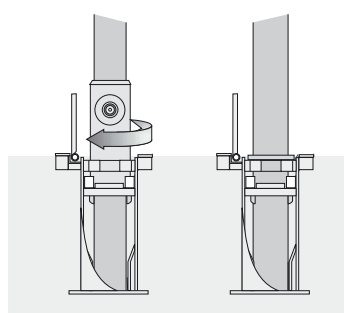
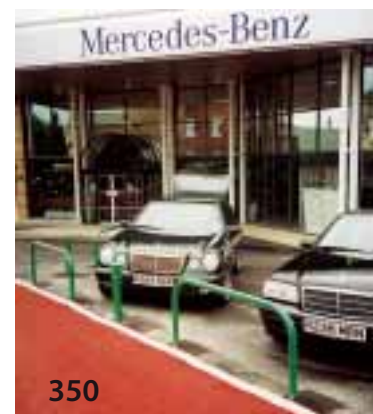

351

350

Retail systems



POLYMER RING BOLLARDS

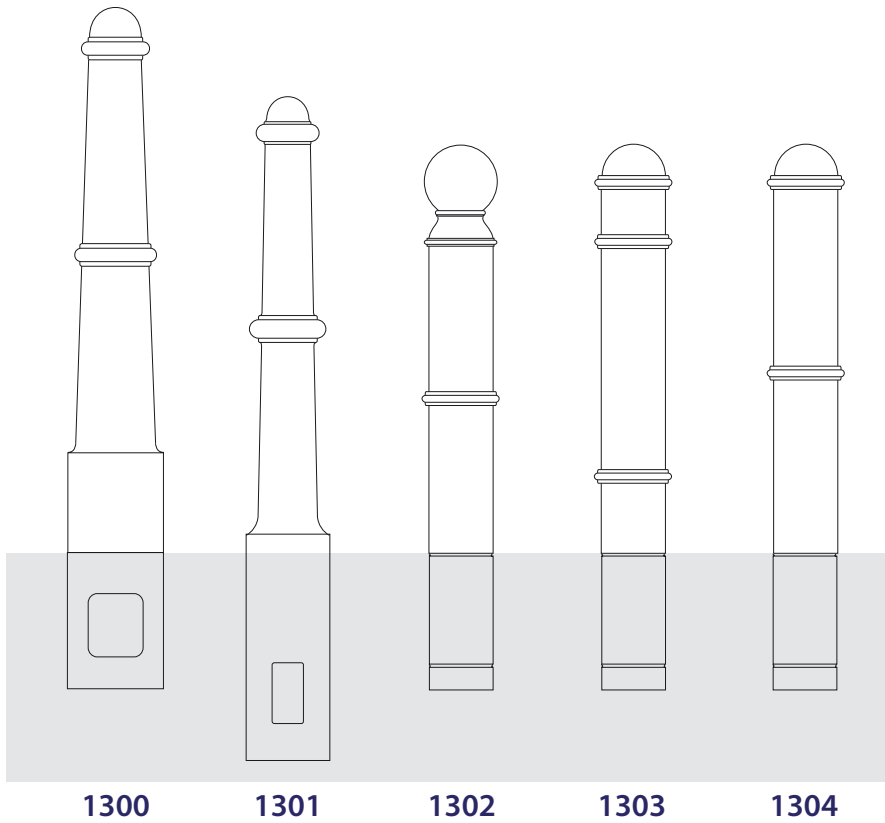

Any feature ring can be replicated as shown on the above cut away sample. The cast iron ring is removed from the standard bollard, a mould is secured and a castable polymer solution poured in. After solidification the mould is removed, leaving an impact absorbing ring feature. This can then be painted in the bollard colour.



In response to the damage caused to bollards in retail parks by trolleys, CIS Street Furniture has developed a method of casting on a polymer ring feature to all types of cast bollards. This feature is designed to integrate with the overall aesthetics of the bollard, whilst retaining impact absorption qualities for trolleys and other vehicles.

STAINLESS STEEL BOLLARDS

These bollards are becoming increasingly popular in retail environments as they are extremely resilient to trolley damage and require minimal maintenance. They can be supplied polished, brushed or even part painted.

Simple contemporary designs and shapes are easily created. Our sales office will assist in designing your own stainless steel bollard.

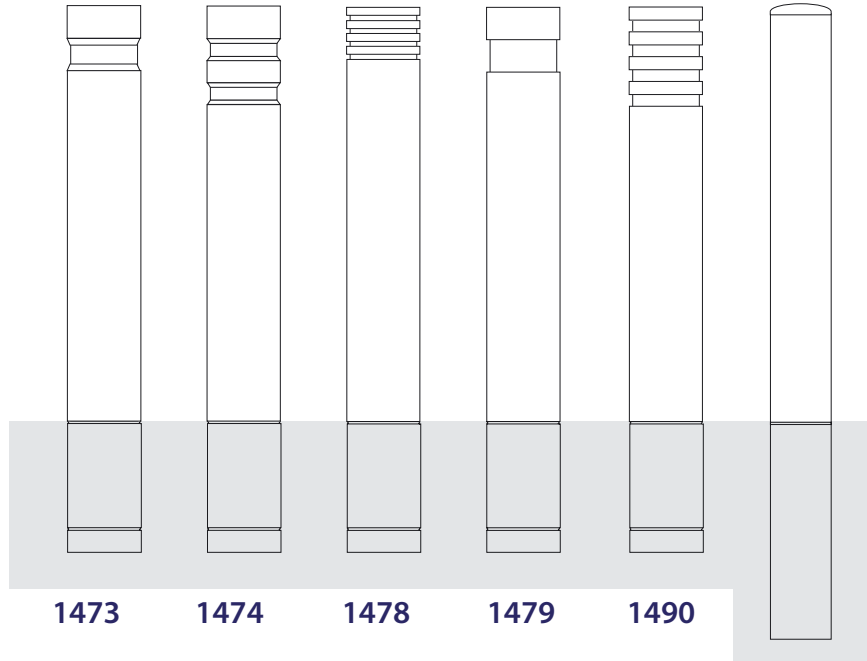

Product dimensions

1400

	height mm	body diameter mm	root depth mm
1400	900	101	300
1401	1000	140	500
1473	950	168	300
1474	950	168	300
1478	950	168	300
1479	950	168	300
1490	950	168	300

TROLLEY PARKS

Trolley parks can either be manufactured from single galvanised mild steel tubes, stainless steel tubes or as illustrated a range of railing posts are available for use.



Retail systems



RECYCLED PLASTIC BOLLARDS

We have a new range of recycled plastic bollards.

These are all manufactured from 100% post-consumer waste. A special paint is bonded directly to the colour-pigmented surface giving excellent abrasion resistance. Almost any style of bollard can be accommodated, a few of which are illustrated.

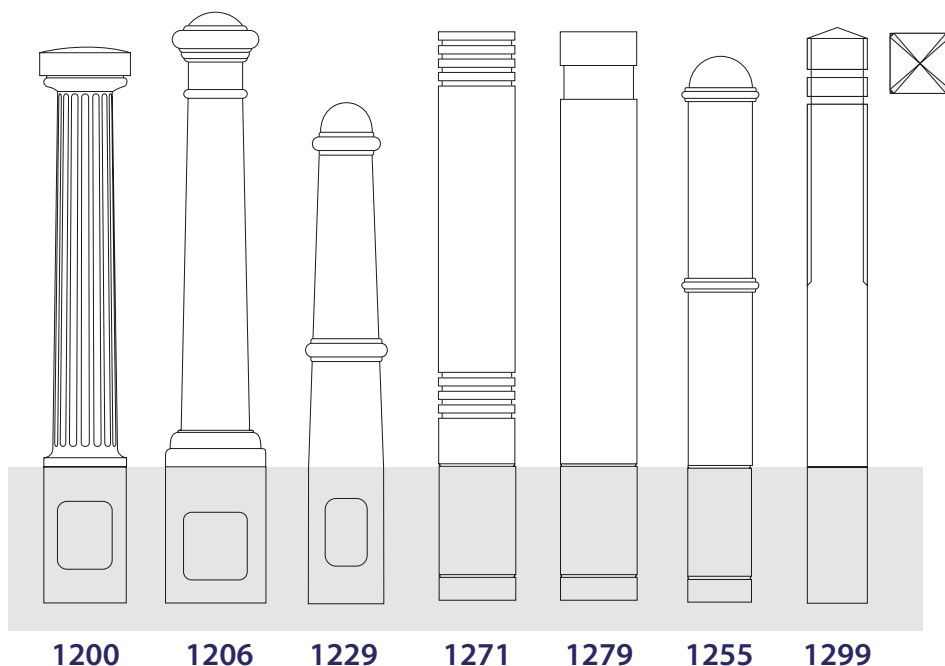

FOLDING BOLLARDS

Type 194 is a folding coffin box design. When not in use the bollard sits in a below ground box. With simple lift and drop movement the bollard is locked in the vertical position. A range of different tops can be supplied to match other cast bollards from our range.

The 197 design of folding parking bollard is useful for the security of vehicles and parking bays. The sliding mechanism gives this bollard excellent strength without solely relying on a padlock.

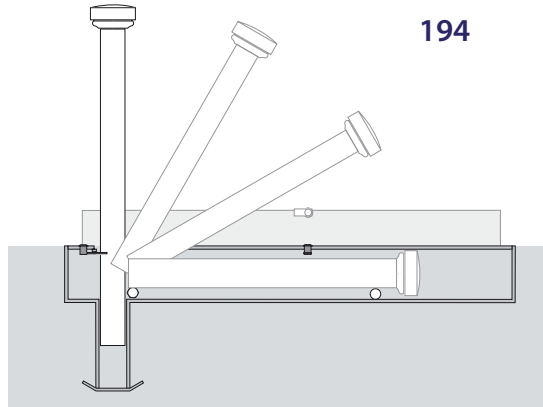

194



Product dimensions

	height mm	base diameter mm	root depth mm
194	750	90	450
197 *	750	70	450
198 *	800	70	1000

* stock item

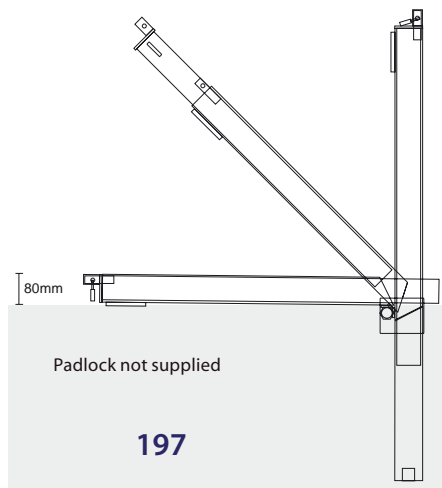

197



Bollards

TELESCOPIC BOLLARDS



Product dimensions

	height above ground mm	depth below ground mm	post width mm	wall thickness mm	Description
1901	500	670	76ø	4	Driveway post, not anti-ram
1902	670	930	90ø	5	Round telescopic security post
1903	670	930	90ø	8	Round telescopic anti-ram security post
1904	850	1110	114ø	5	Round telescopic anti-ram security post
1905	670	930	90/90	5	Square telescopic security post
1906	670	930	90/90	8	Square telescopic anti-ram security post
1907					Lockable head

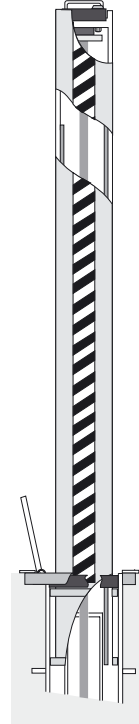

1903

A range of telescopic bollards is available.

During daytime they are most inconspicuous, hidden below ground level.

A high security key operation locks the bollard in the up position.

These bollards are available as round or square and vary in duty from simple access control to outright ram raid control.

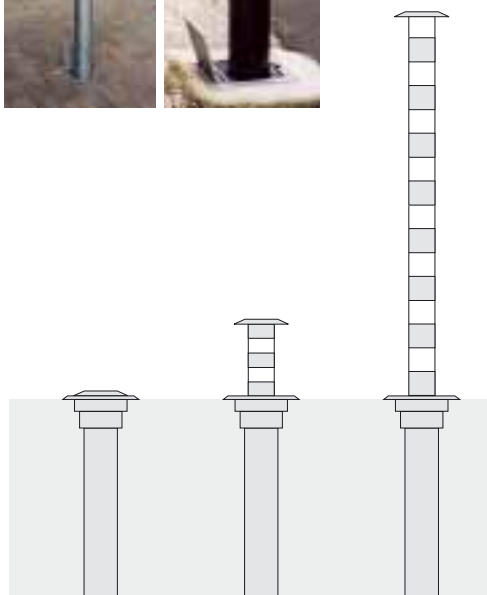

198



The 198 telescopic bollard is mainly used for access control. It features an assisted lifting mechanism with dual locking system and is guaranteed as 'non freeze' during winter. The internal mechanism is hydraulically damped by anti-freeze. This product has been proven in the sub zero temperatures of Scandinavia.

CYCLE STANDS

CIS Street Furniture has responded to the growth in cycleways throughout the UK by producing a vast arrangement of cycle parking products.



181 + 100

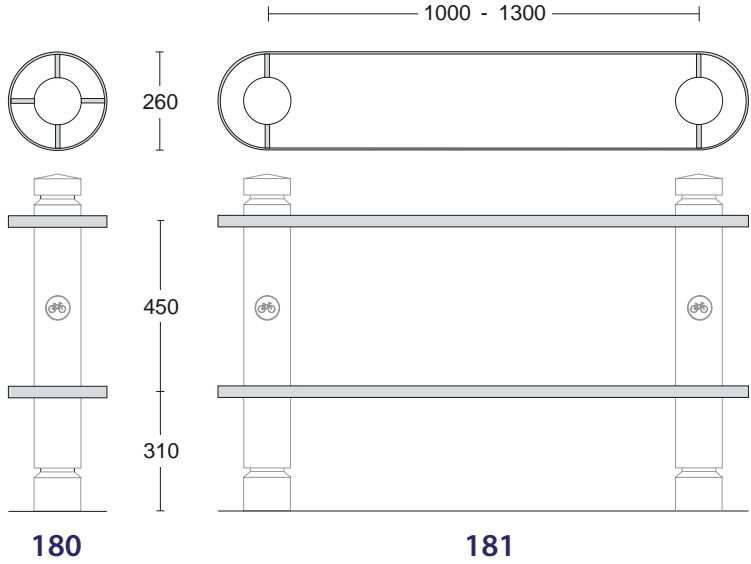

Designs vary from the simple 'Sheffield' U shape cycle stand to single and multiple cross tubes giving several locking points. Cycle parking logos can be accommodated within the design of the bollard.

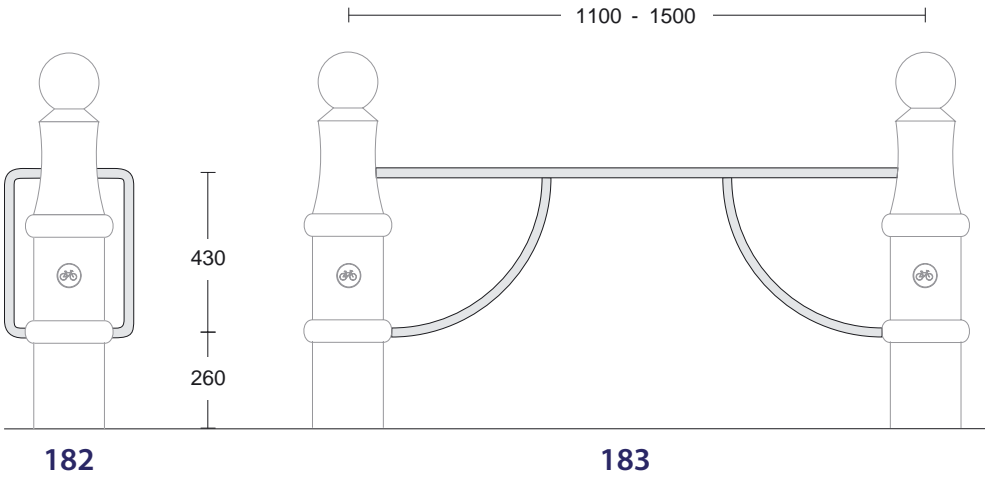

182 + 108



183 + 108

Bollards

CYCLE STANDS

The most popular cycle stand is the type 187 and is available from stock. This is illustrated as rooted but is also available flanged (187F). This type of cycle rack is most visually attractive in a stainless steel finish (187ss).



184ss + 1490

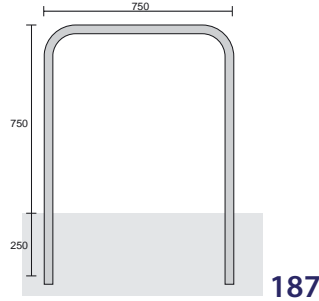

187



184

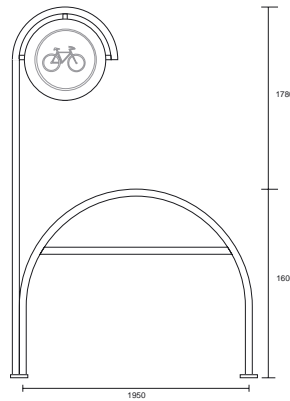

185



185

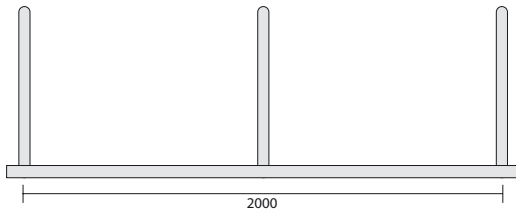

186

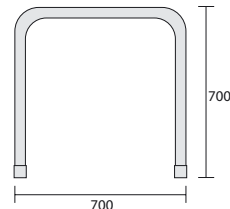

184 + 150



187 ss



184 + 1502



187

HINGED GATES

Gate design type 301 uses a simple traditional hinging method for hanging the gate on a bollard. However this can cause undue stress to both the bollard and hinge mechanism. This type of gate is only suitable for hanging up to 1.8m long gate leaves.

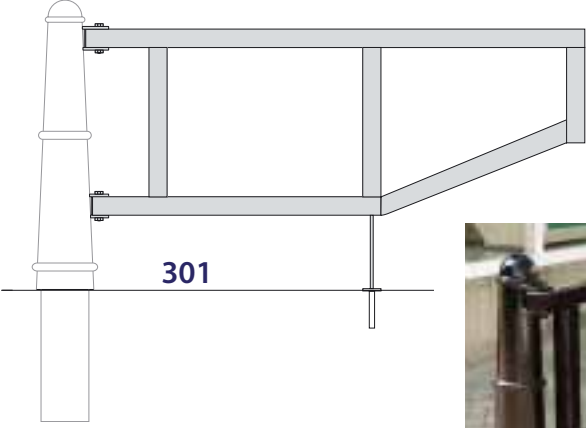

103 + 301

PIVOTING BOLLARD GATES

In response to the above limitations we have developed a range of pivoting bollard gates, explained on page 1.31.

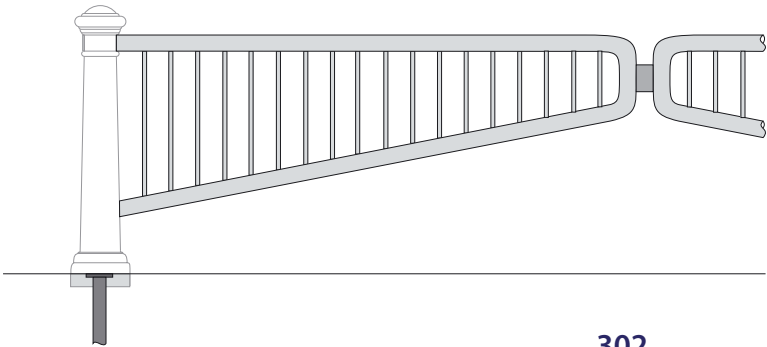

302



106 + 302



106 + 302

Bollards

PIVOTING BOLLARD GATES

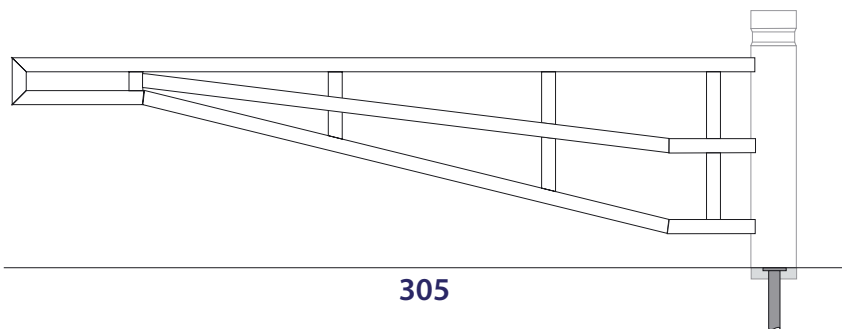
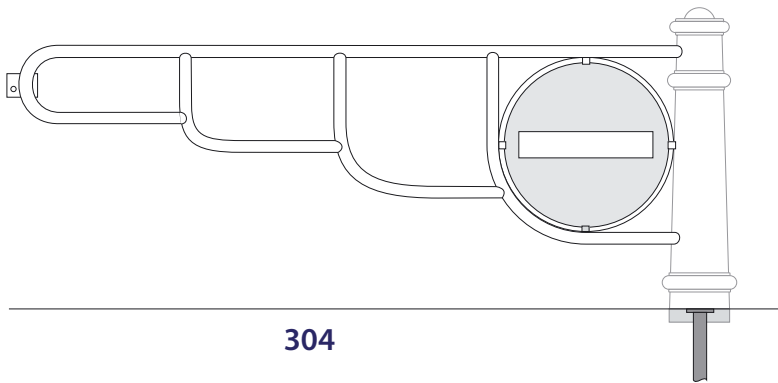
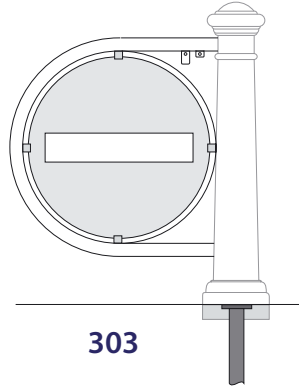

By utilising a bearing in the top portion of the bollard the whole assembly pivots around an internal steel core. With no external moving parts strength and durability are greatly increased.

These gates are suitable for single leaf spans of up to five metres. Drop bolts or intermediate bollards can be provided to give extra support. We would also recommend the use of slam posts in order to lock the gate in the open position where single leaves are in excess of three metres.

Provision for locking can be made either on the end of larger gates (i.e. three metres or over) or by simple tabs on the base that can be made to restrict opening to either 90°, 180° or 360°.



Certificate Number FM 32898

CIS Street Furniture
Albany Court
Blenheim Road
Airfield Industrial Estate
ASHBOURNE
Derbyshire
DE6 1HA

T: 01335 300234

F: 01335 300353

E: sales@cis-streetfurniture.co.uk

W: www.cis-streetfurniture.co.uk

Use of cover photo by courtesy of Macdonalds (Restaurants) Ltd.



Fixings

All fixing details and foundations are purely advisory. Ground and service conditions may vary locally. We advise you to consult a structural engineer if in any doubt.

In line with our policy of continual improvement, we reserve the right to change, without prior notice, any of the data contained in this publication. The information given is believed to be correct at the time of printing.

CIS Street Furniture is a trading name of DKT Group Ltd. All rights reserved. Neither whole nor part of this publication may be copied without the written permission of the publishers. The designs are the property of DKT Group Ltd and may not be reproduced without express permission. © September 2000.