

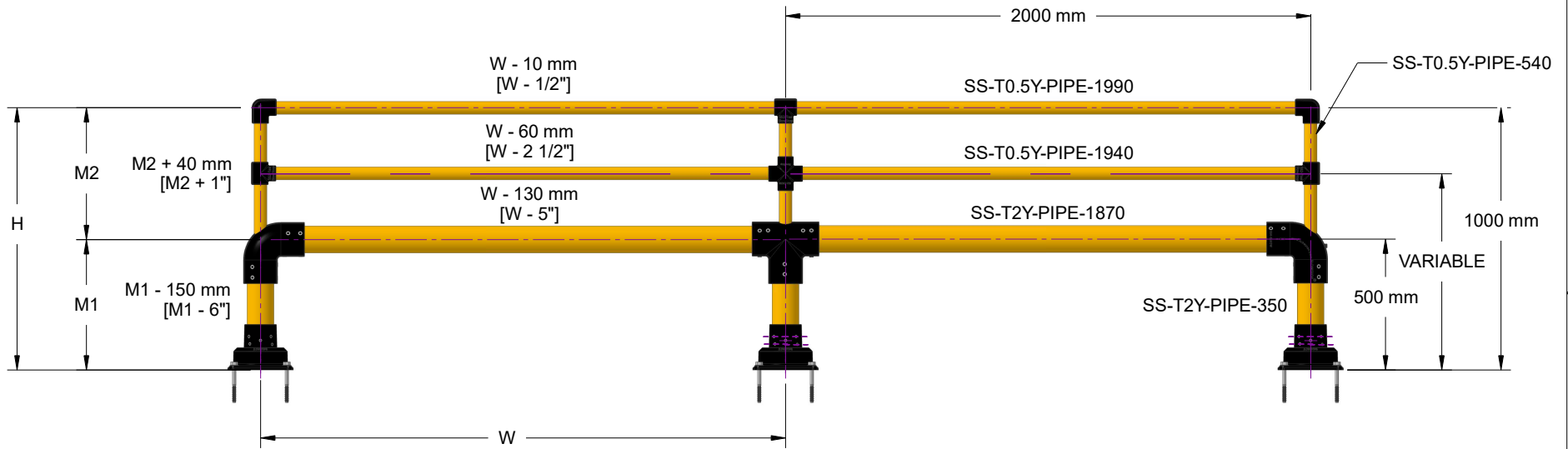

NOTES:

- 1. ALL MEASUREMENTS ROUNDED TO THE NEAREST 10MM / 0.5"
- 2. PIPE LENGTHS ARE FROM DESIRED CENTERLINES
- 3. UPPER HANDRAIL PIPE SHOULD REST ON VERTICAL ELEMENTS
- 4. MIDDLE HANDRAIL HEIGHT IS ADJUSTABLE

METRIC EXAMPLE



CONFIDENTIAL & PROPRIETARY

©2024 Impact Recovery Systems, Inc. All rights reserved. Products are covered by U.S. and international patents. Other U.S. and international patents pending.

4955 STOUT DR. · SAN ANTONIO, TX 78219 · (800) 736-5256

SIZE
A

PART NO.

SCALE

DWG.
**SLOWSTOP TYPE 2 (4") HANDRAIL
PIPE CALCULATIONS**

SLOWSTOP GUARDING SYSTEMS, LLC

DATE 08-DEC-2023

REV
1.1

